

Pressure Unloading Valve, Size 10

$Q_{max} = 60 \text{ l/min}$, $p_{max} = 315 \text{ bar}$

Two-stage, various on-off pressure differentials, optional soft-switching version

Series DWPA..., DWPBU...



- Compact construction for cavity type DD – M24 x 1,5
- Choice of 5 on-off differentials
- 3 pressure ranges available
- With integral pressure-relief function
- Optional soft-switching model is available
- All exposed parts with zinc-nickel plating
- Can be fitted in a line-mounting body

1 Description

Series DWPA... and DWPBU... cartridges are size 10, two stage, high performance pressure-unloading valves with an M24x1.5 mounting thread. They consist of a spool-type main stage and a leak-free, ball-type pilot stage. Unloading valves are used wherever a pump has to be disconnected from and re-connected to a pressure circuit. For this purpose, either the 'Off' pressure or the 'On' pressure of the cartridge can be set. When the 'Off' pressure is set, the 'On' point will depend on the selected percentage on-off differential, or the other way round. To disconnect the pump, the cartridge responds to rising pressures at ports A and X by opening the connection from A → B. This connection is then kept open until the selected percentage on-off differential is reached (falling pressure at port X) and the connection

A → B closes again (the 'On' point). The changeover to unloaded bypass can be made less harsh (soft switching) by using the DWPBU... model with damped switching characteristics, which is available as an alternative. These unloading valves are predominantly used in accumulator-charging circuits, 2-pump systems, and circuits for fast-advance → feed changeover, and in such cases the cartridges also provide a pressure-relief function e.g. for protecting the pump (see the application examples). All external parts of the cartridge are zinc-nickel plated according to DIN EN ISO 19 598 and are thus suitable for use in the harshest operating environments. If you intend to manufacture your own cavities or are designing a line-mounting installation, please refer to the section "Related data sheets".

2 Symbol

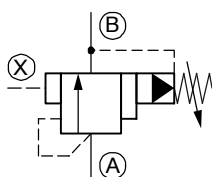

3 Technical data

General characteristics	Description, value, unit
Designation	pressure unloading cartridge valve
Design	two-stage, with manual adjustment, various on-off pressure differentials, optional soft-switching version
Mounting method	screw-in cartridge M24 x 1.5
Tightening torque	Can be fitted in steel 65 Nm ± 10 % Can be fitted in aluminium 50 Nm ± 10 %
Size	nominal size 10, cavity type DD

General characteristics	Description, value, unit
Weight	0.48 kg
Mounting attitude	unrestricted
Ambient temperature range	-25 °C ... +80 °C

Hydraulic characteristics	Description, value, unit
Maximum operating pressure	315 bar
Maximum flow rate	60 l/min
Nominal pressure ranges	L = (40...110 bar), M = (80...210 bar), N = (180...315 bar)
On-off differentials ¹⁾ (on-off differential from 'Off' (unload) pressure)	8 ... 12 % (pressure ranges M and N only) 13 ... 17 % 17 ... 23 % 27 ... 33 % 37 ... 43 %
Flow direction	A → B, see symbols
Hydraulic fluid	HL and HLP mineral oil to DIN 51 524; for other fluids, please contact BUCHER
Hydraulic fluid temperature range	-25 °C ... +80 °C
Viscosity range	10...650 mm ² /s (cSt), recommended 15...250 mm ² /s (cSt)
Minimum fluid cleanliness Cleanliness class to ISO 4406 : 1999	class 20/18/15



ATTENTION! ¹⁾

Any back-pressure in port B (tank) directly reduces the on-off pressure differential.
Recommended back-pressure ≤ 1 bar.

4 Performance graphs measured with oil viscosity 33 mm²/s (cSt)

$\Delta p = f(Q)$ Pressure drop - Flow rate characteristic
(for unloaded bypass, valve open)

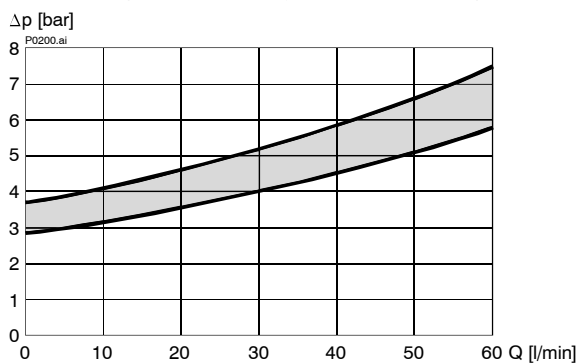

$\Delta p = f(Q)$ Pressure drop - Flow rate characteristic
(pressure-relief function)

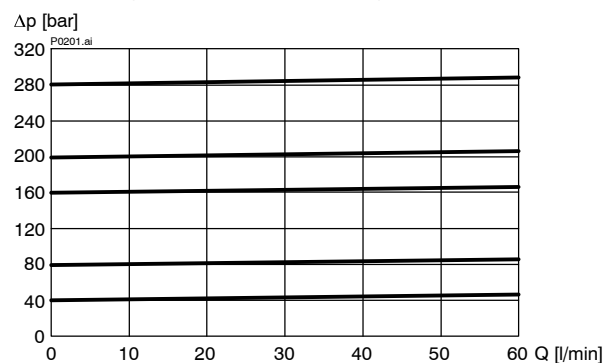

$p = f(Q)$ Performance limits
On-off differential 8 ... 12 %

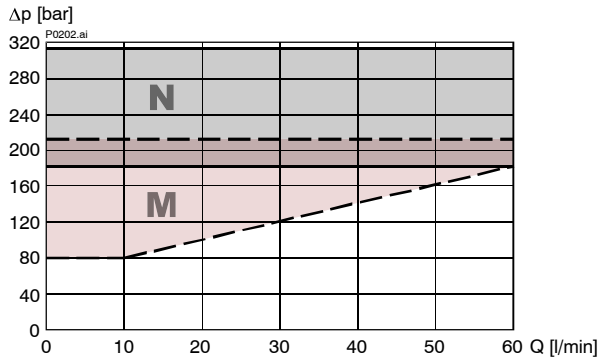

$p = f(Q)$ Performance limits
On-off differential 13 ... 17 % / 17 ... 23 %

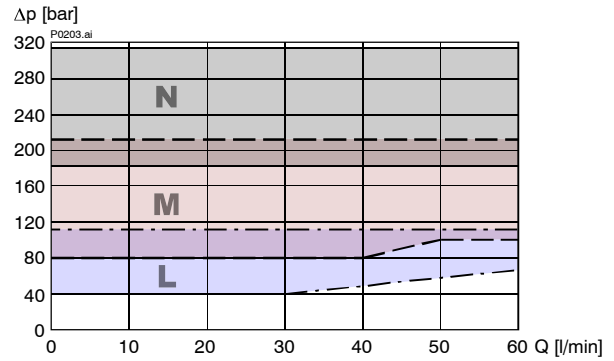

$p = f(Q)$ Performance limits
On-off differential 27 ... 33 % / 37 ... 43 %

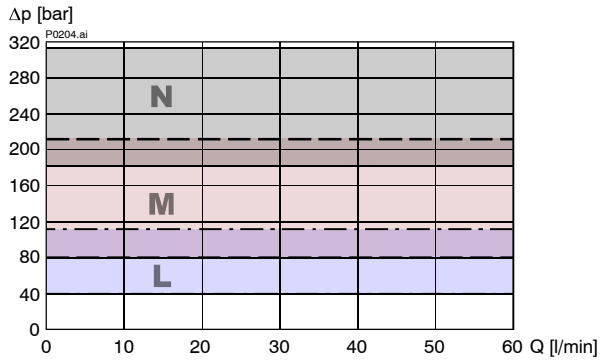

5 Dimensions & sectional view

Standard model: DWPA...

Model: DWPBU... (soft switching)

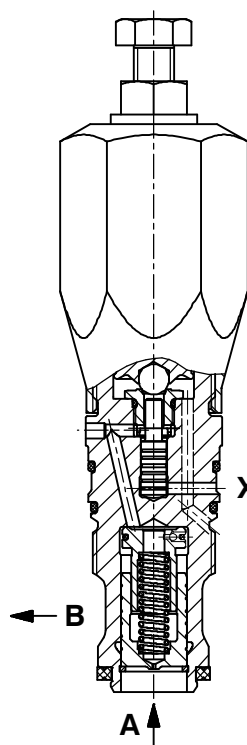
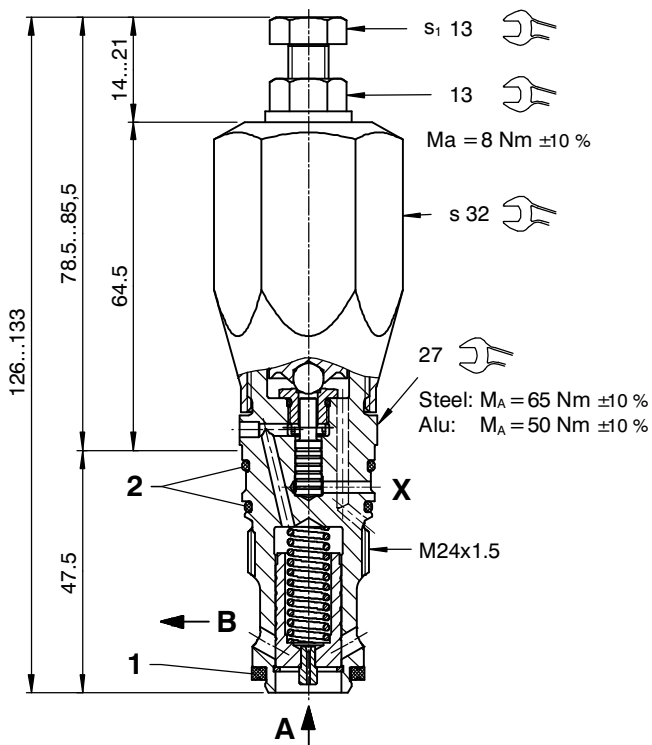

6 Installation information



IMPORTANT!

When fitting the cartridges, use the specified tightening torque. Set the switching point by means of the adjusting screw (s_1). Either set the 'Off' pressure, in which case the 'On' pressure will depend on the selected percentage on-off differential, or the other way around. After you have set the valve, lock the adjusting screw with the lock nut.



ATTENTION!

Type DWPBU-2... (soft switching) pressure-unloading cartridges are not suitable for use in applications with 2-pump systems or circuits for fast-advance → feed changeover.



ATTENTION!

Only qualified personnel with mechanical skills may carry out any maintenance work. Generally, the only work that should ever be undertaken is to check, and possibly replace, the seals. When changing seals, oil or grease the new seals thoroughly before fitting them.

Seal kit NBR no. DS-216-N ²⁾

Item	Qty.	Description
1	1	Seal ring $\varnothing 22,10 / 16,50 \times 2,50$
2	2	O-ring no. 020 $\varnothing 21,95 \times 1,78$ N90



IMPORTANT!

²⁾ Seal kit with FKM (Viton) seals, no. DS-216-V

7 Application examples

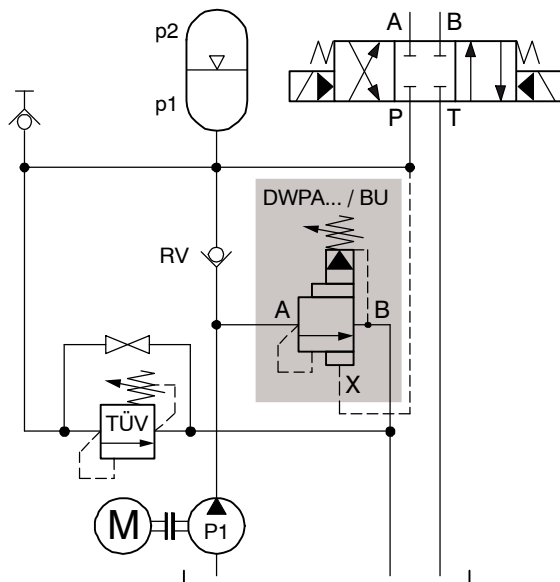

p1 = 'On' pressure

p2 = 'Off' pressure

Accumulator-charging circuit

In this application, the DWPA-2... unloading cartridge performs an automatic accumulator-charging function in response to the pressures at ports A and X. Here, the normal procedure is to use the adjusting screw to set the upper, 'Off' pressure p2, and when this pressure is reached the pump will therefore be switched over to unloaded bypass (connection A → B open). The 'Off' pressure p2 and the on-off differential (10...40 %) determine the lower, 'On' pressure p1. When demand causes the pressure in the accumulator circuit to fall to p1, the unloading cartridge closes the connection A → B and the pump supplies oil to the accumulator circuit until the 'Off' pressure p2 is reached and another 'unload' occurs.



IMPORTANT!

The changeover to unloaded bypass can be made less harsh (soft switching) by using the optional DWPBU-2... model.

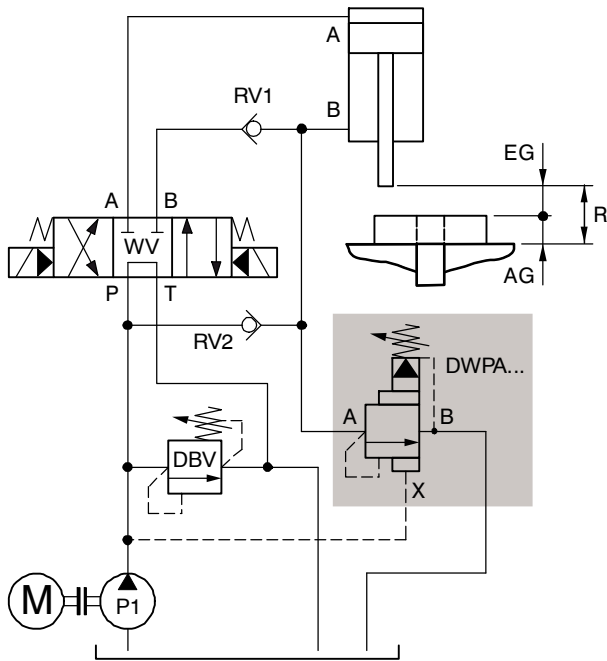

EG = fast-advance speed
 AG = feed speed
 R = return stroke

Pressure-dependent fast-advance → feed changeover with 1 pump

In this application, when the directional valve (WV) is in its parallel-arrows position, the unloading cartridge DWPA-2... remains closed until the valve pressure setting is reached, and oil discharging from the rod end of the cylinder is routed to the head end, where it supplements the pump delivery (fast-advance circuit). When the pressure at ports A and X rises above the setting, the unloading cartridge opens the connection A → B and the oil from the rod end flows to tank with virtually no back-pressure. This cancels the fast advance, and the cylinder's potential force is automatically increased (feed-speed circuit). The maximum force is limited by the pressure-relief valve (DBV) positioned on the primary side. When the directional valve (WV) is in its crossed-arrows position, the unloading cartridge is closed and the cylinder can be in-stroked again.



ATTENTION!

DWPBU-2... cartridges are not suitable for automatic fast-advance → feed changeover circuits.



IMPORTANT!

The changeover from fast to slow speed means a reduction in flow rate, which is often accompanied by a sharp drop in system pressure. We therefore recommend the use of unloading cartridges with an on-off differential of 20 %...40 %.

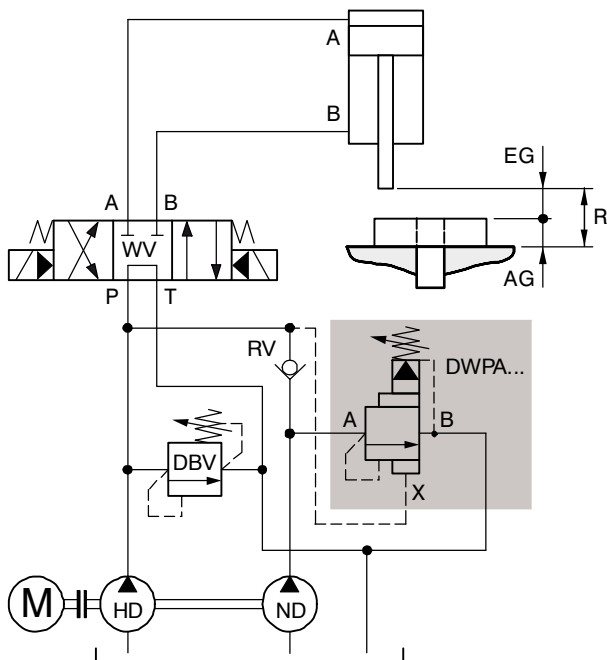

EG = fast-advance speed
 AG = feed speed
 R = return stroke

High-/Low-pressure circuit with two pumps

There are applications with one high-pressure pump and one low-pressure pump where the load pressure is used to automatically change the cylinder out-stroke speed from fast to slow. The DWPA-2... unloading cartridge is used here to switch the low-pressure pump 'Off' i.e. to unloaded bypass. When the cylinder is in-stroked, the low-pressure pump is brought back on-load again, provided that the dynamic load pressure is less than the 'Off' pressure that has been set at the unloading cartridge.



ATTENTION!

DWPBU-2... cartridges are not suitable for use in 2-pump systems.



IMPORTANT!

We strongly recommend that unloading cartridges with an on-off differential of 30 %...40 % be used in all applications of this type.

8 Ordering code

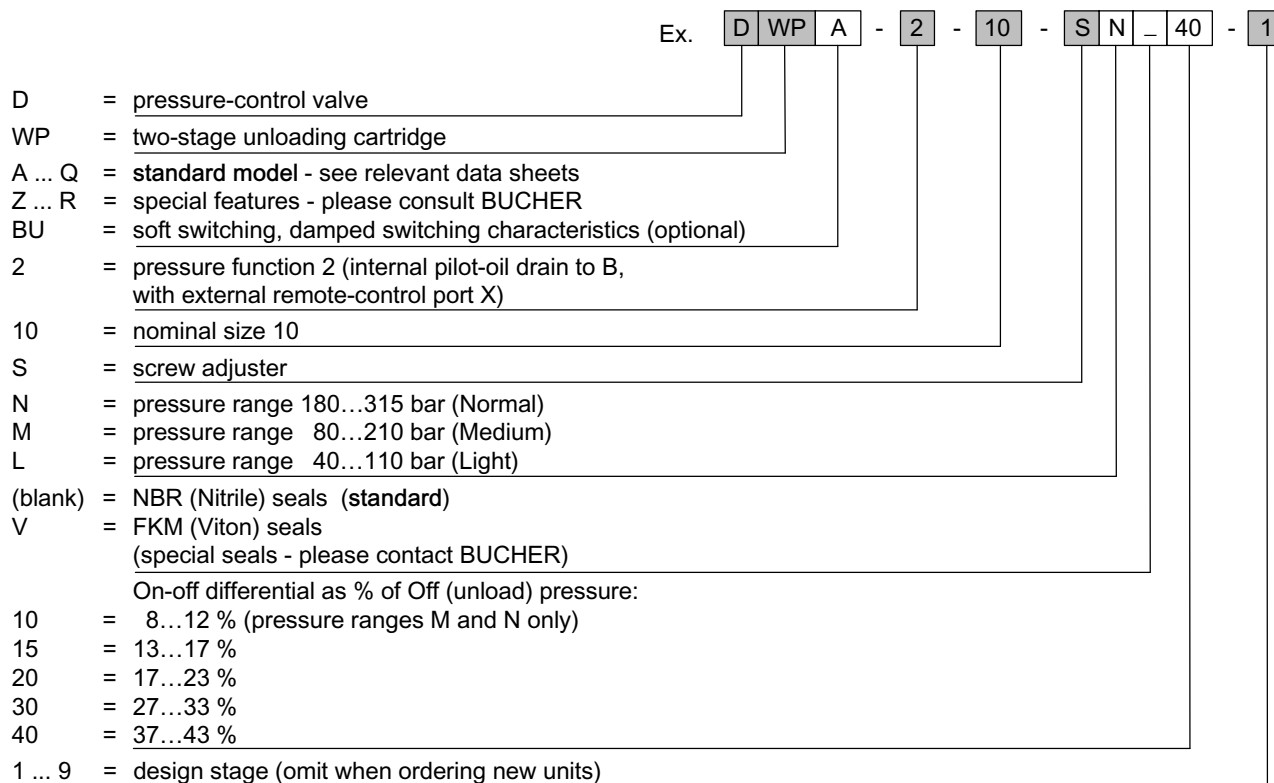

9 Related data sheets

Reference	(Old no.)	Description
400-P-040011	(i-32)	The form-tool hire programme
400-P-060121	(i-45.2)	Cavity type DD
400-P-740111	(G-24.21)	Line- and manifold-mounting body, type DD-12 (G 1/2")

info.ch@bucherhydraulics.com

www.bucherhydraulics.com

© 2021 by Bucher Hydraulics AG Frutigen, CH-3714 Frutigen

All rights reserved.

Data is provided for the purpose of product description only, and must not be construed as warranted characteristics in the legal sense. The information does not relieve users from the duty of conducting their own evaluations and tests. Because the products are subject to continual improvement, we reserve the right to amend the product specifications contained in this catalogue.

Classification: 430.305.315.305.320.355